

# Research and development project for practical use of robotic travel aid for the visually impaired

H Mori<sup>1</sup>, S Kotani<sup>2</sup>, K Saneyoshi<sup>3</sup>, H Sanada<sup>4</sup>, Y Kobayashi<sup>5</sup> and A Mototsune<sup>6</sup>

<sup>1,2</sup>Department of Electronic Engineering, University of Yamanashi, Takeda-4, Kofu, Japan

<sup>3</sup>Tokyo Institute of Technology, Radioisotope Research C.4259, Nagatsuda Midori-ku, Yokohama, Japan

<sup>4</sup>Musashino Art University, Industrial Design, 1-736, Ogawa-cyo, Kodaira-shi, Tokyo, Japan

<sup>5</sup>Hitachi Ltd., Hitachi Research Laboratory, Oomika7-1-1, Hitachi, Japan

<sup>6</sup>Nippon Systemware Co. Ltd., Yamanashi IT center707, Ichinokura, Ichinomiya, Yamanashi, Japan

(<sup>1</sup>forest,<sup>2</sup>Kotani)*@es.yamanashi.ac.jp*, <sup>3</sup>ksaneyos*@ric.titech.ac.jp*, <sup>4</sup>sanada*@musabi.ac.jp*,  
<sup>5</sup>kobaya*@hrl.hitachi.co.jp*, <sup>6</sup>amotots1*@gw.nsw.co.jp*

<sup>1,2</sup> <http://www.harumesa.yamanashi.ac.jp/>

## ABSTRACT

Destined to the visually impaired, Robotic Travel Aid (RoTA) acts as an intelligent cart, guiding people across the streets. The 60 Kg, one-meter tall mobile robot is equipped with computer vision system, stereo camera sensor and voice interface. When moving, it is aware of its environment: It recognizes landmarks such as zebra crossing marks or traffic signals, stopping when the light is red, and “sees” cars or other pedestrians. In case of trouble, the robots communicates wirelessly with a Service Center, allowing to give extra information on the trajectory and adapt the navigational information system.

## 1. INTRODUCTION

Among 305,000 visually impaired people in Japan, about 170,000 people who lose their sight in elderly age cannot walk with either a long cane or guide dog. Most of them stay in their home and do not go outside by themselves. The guide helper of city hall and the volunteer group such as Japan Blind person Outdoor Support association helps them to go traveling. But when they want to go for walk or go shopping in daily life, they are not able to apply the guide helper system. In the large hospital or the home for the senior citizens the inpatient of visually impaired requires a nurse to move from his/her bed to somewhere else. To move when and where he/she wants, the device for mobility, orientation and navigation is developed (K. Melen.1998). One of the solutions of the above requirements is the guide dog. But it requires training by the guide dog center. Its cost is estimated about \$40,000 in Japan. The user of the robot is required cares such as feeding, brushing and health care. The care cost is estimated \$3600 /year.

The intelligent wheelchair navigation system (SENARIO) is developed to guide the visually impaired in the indoor (N.Katevas, 1998). Also the personal adaptive mobility aid (PAM-ID) is developed for the same purpose (A.O’Neill, 1998). The aim of our project is to provide a mobile guide robot for the visually impaired when he/she goes for walk near his/her home or walk in the hospital or senior home. Twenty of RoTAs are produced to evaluate the robot in the real environment by the visually impaired of various level and to get the data for service and maintenance. RoTA is not for the visually impaired people who can walk with the long cane or the guide dog but for ones who cannot go outside without a helper.

## 2. DESIGN POLICY

We made the plan of R & D project of RoTA for one who cannot use the long cane and the guide dog. Its design policy is as follows:

- 1) *Mobility support*: One who loses one's sight is difficult to stand straight. The robot should be enough weight to support one's posture.
- 2) *Sensing for the mobility*: To get the mobility information such as the boundary of the road or the obstacle location, the robot should have a stereo sensor in the outdoor or infrared sensor in the indoor.
- 3) *Sensing for the orientation and landmark*: To get the orientation information such as the longitudinal direction of the road and crossing, the computer vision system is required (S.Kotani, 1996). It is also useful to identify the landmark and the traffic signal.
- 4) *Sensing for the obstacle avoidance*: In the road environment the robot should detect the car and the motorcycle. For this purpose the shadow underneath the vehicle is detected as the sign pattern (H.Mori, 1994, S. Kotani,1996). Both in the outdoor and in the indoor the robot should detect the pedestrian. For this purpose the rhythm of the foot is detected as the sign pattern (H.Mori, 1994, S.Yasutomi, 1996).
- 5) *Safe navigation*: For the safe navigation, the robot should follow the safer route from the start to the goal and follow the traffic regulation. For this purpose the route map specialized for the robot is required.
- 6) *Teaching the route map*: The digital map made for the car navigation is not useful for the robot, because it does not represent the sidewalk and the cross walk. The operator of the normal sight has to select the safer route and make the route map. It takes much work and time to measure the significant point by the instrument. To solve this problem, the route map should be made by manually moving the robot along the route to memorize the mobility, orientation and navigation information.
- 7) *Communication before start*: Before start one has to select the route by assigning the start point and the goal to the robot, and may ask how much time it takes to reach the goal. To make communication the robot should have non-visual human interface other than the display and keyboard.
- 8) *Communication after start*: The auditory sense is the most important sense for the echolocation among the residual senses. The robot should give him/her the information about the mobility and the orientation by its motion. In addition the vibrator should use to give him/her the orientation
- 9) *Battery*: The visually impaired may walk less than two hours every day. The robot should move two hours by one charging. During the stop at the sub-goal the robot should be power saving mode.
- 10) *Friendly looks*: The passenger and the driver near the robot are expected to give way. Therefore the robot should have noticeable and friendly looks
- 11) *Service center*: The service center is required to feed RoTA with the route information and to check and repair its breakdown.

### 3. SYSTEM CONFIGURATION

Following the above design concepts RoTA is developed. It is a motored cart of 500mm in width, 950mm in height, 1000mm in depth and 60kg in weight and is able to move 2 hours in the velocity of 2-4km/hour. It is equipped with a color vision system for road recognition, a stereovision system or infrared system for the obstacle detection, sonar systems and bumper sensors for collision avoidance, a rear handle for supporting the balance of walking. Vibrators are attached to the both side of the handle to inform the user which side the robot is going to turn. A speaker and four push buttons are used for the menu input; in addition a voice recognizer is for the start point and goal input. Figure 1 shows RoTA's system configuration. Figures 2 and 3 show the photo of the RoTA and its handle and push buttons.

In the case of the teaching a note pc with a head-mount display and joystick are equipped. At first the operator of well sight performs the route map teaching of RoTA. In the teaching he moves RoTA on the sidewalk from the start point to the goal or sub-goals and teaches it a sign pattern along which it should move and landmarks by which it verifies the route. A part of the route is called *path* when the part is specified by the same sign pattern and the same navigation mode. The route is represented by a chain of the paths that written by XML.

### 4. THE ROUTE

The route from the start point to the goal is represented by a chain of path or path and landmark. The path is represented a line segment of trace with sign pattern. Even a curved part of the route is represented by a part of polygon.

#### 4.1 Sign pattern and Landmark

The longitudinal visual feature along which the path lies is called *Sign Pattern* (SP in abbreviation) in this paper. In the road environment, the elongated feature on the road such as the boundary, the lane mark or the tactile block is a sign pattern. In the corridor the narrow board fixed at the lower part of the wall is a sign pattern.

Landmarks are grouped in three types (1) used for the current location correction in the position, (2) used for matching the current location up to the route, (3) used for the decision of go-stop. The crossing mark is one of the first types of landmark. The advertisement remarkable in the color is one of the second types. The traffic signal or the door of elevator is one of the third types.

#### 4.2 Teaching

At first we were going to make the route data from the digital map of ZENRIN 1/1500, because it shows the road, sidewalk and crossing in detail. But the work failed because the map represents the road only in the image, not in the vector format. It is very difficult to identify the sidewalk and crossing in the image by the computer vision. Next we tried to make the route data by measuring the significant points by the instrument of the civil engineering. It took one hours to measure several points. Moreover the measurements in the road are very dangerous and disturb the traffic. In this project the operator of the right sight selects the significant points and the SPs and the landmarks, and the robot measures its location and the parameters for the computer vision with its built-in instruments. We find it useful because (1) the data of the teaching and the practice are made with the same instruments, (2) measuring by the robot takes less time than that by the engineering instruments, (3) the measuring by the robot disturbs less the traffic than that by the engineering instruments.

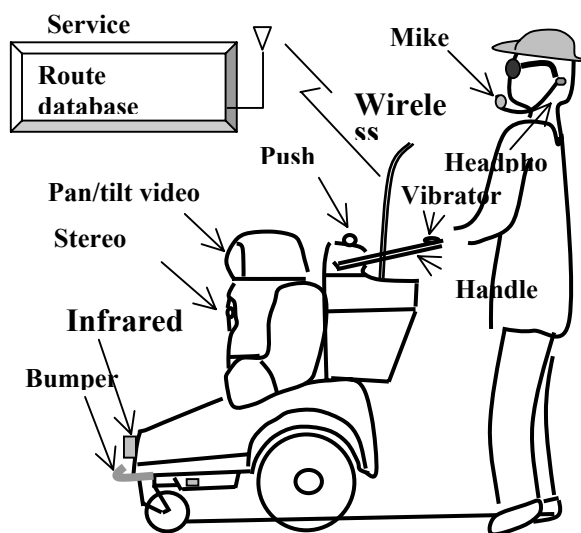

Figure 1. Configuration of RoTA.



Figure 2. RoTA.

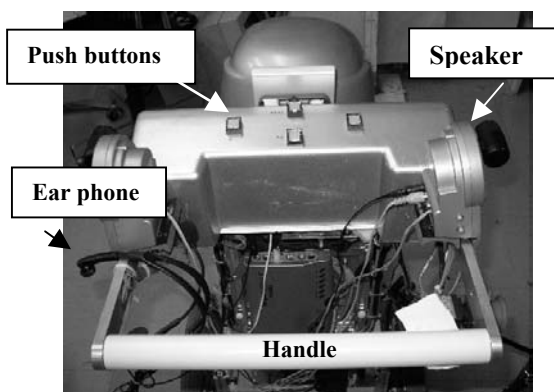

Figure 3. Handle and push buttons.

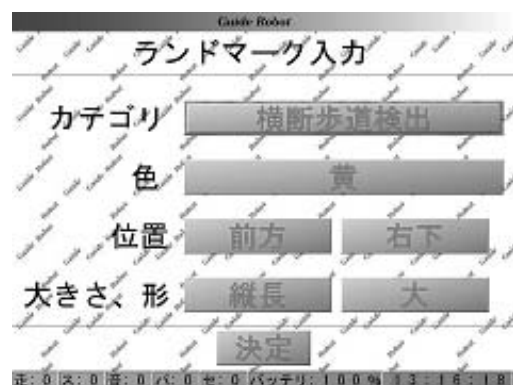
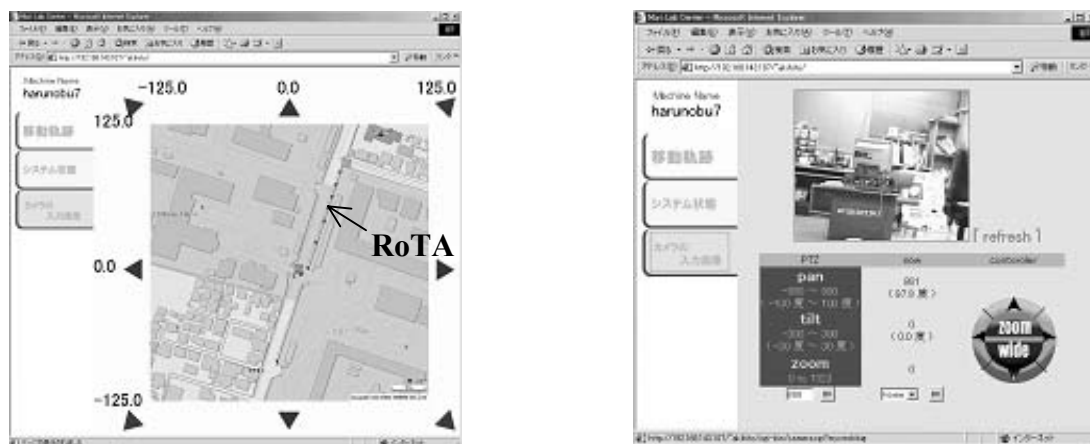

Figure 4. Display example in teaching.

The operator takes the head-mount display and moves the robot by manually control with the joystick, stops at the significant point and pushes the menu button. Fig.4 shows the image of the head-mount display. By pushing one of the menu buttons he selects the right icon or he inputs numerical data through the keyboard of PC. Fig.5 show display examples of the service center PC during the teaching. Fig 5 (a) and (b) show a RoTA trace on the map and a video image transmitted from RoTA during the teaching,



(a) A RoTA trace on the map.

(b) A video image transmitted from RoTA.

**Figure 5.** Display examples of the service center PC during the teaching.

Line (3)-(6): Selecting the menu the operator specifies the navigation information that shows the locomotion pattern (GO-STRAIGHT, BACK, and SPIN-TURN) and the traffic regulation

Line (7)-(14): Selecting the menu the operator specifies the road information that shows the kind of road (INDOOR, OUTDOOR, SIDEWALK, ROAD-WITHOUT-SIDEWALK, CROSSING, ELEVATOR) the pavement (ASPHALT, BLOCK, LINO-LEUM, OTHERS) and the width of the path (line (10)-(13)).

Line (15)-(27): The operator fixes the start point of the path and the end point of the path. The data of both points (Line (16)-(20) and Line (21)-(25)) are given by the robot itself.

Line (28)-(56): The SP information is shown. Line (29)-(32) specifies the creation date (year, month, date) and the weather (FINE, CLOUDY, RAINY, SNOW). The former is given by the robot and the later is given by the operator. Selecting the menu, the operator specifies SP module (Line (35)) with its version (Line (36)). The operator directs the camera toward the SP by panning, tilting and zooming (Line (37)-(41)). The lateral distance of the SP from the robot is detected by its image processing system and is assigned in Line (42).

Line (43)-(55): The operator selects the SP in the video image by the menu. The selected point is stored in Line (44)-(48). Its search zone in the image is stored in Line (49)-(54).

## 5. R & D PROJECT FOR PRACTICAL USE OF RoTA

JSPS of Ministry of Education and NEDO of MITI financed 'R&D Project for Practical Use of RoTA for visually impaired.' The purpose of the project is to develop twenty of robots for test in the real environment by the visually impaired people. To make the robot practical it should be robust, power saving and low cost. To fit these requirements, the robot has to consist of as small number of elements as possible. HITACHI LABORATORY developed a small power saving image processing computer SuperIPcam, that consists of DSP (SH-4), vision chip (Super V chip), voice recognition and synthesizer middle ware and IO (Video in/out, Audio in/Out, LAN, RS232C). It operates in UNIX, 12W and 1.5W (in standby). Figs. 7 and 8 show the SuperIPcam configuration and that of Super V chip. Suzuki Motor Corporation Yokohama R&D Center developed a compact wheel built-in DC motor. Nihon Systemware Co. Ltd. developed Vision-based navigation system on SuperIPcam and Service center system on PC of Window. Fig.9 shows the software system configuration of RoTA and the service center. Fig.10 shows an illustration of the RoTA guide. Mori & Kotani Laboratory in University of Yamanashi developed SP & obstacle detection module, LM detection module and Locomotion controller. Saneyoshi Laboratory in Tokyo Institute Technology developed a stereo

camera system for such obstruct detection as pedestrian, bicycle, tree and garbage can. Nakaya-Seisakujo Co. Ltd. developed the undercarriage. Professor Sanada designed the cover and handle of RoTA.

XML Code	Comment	Who	Means
<Date>20000719</Date>	(1) Creation date	Robot	
<PathName>TAKEDA SIDEWALK</PathName>	(2) Path name	Operator	Keyboard
<NaviInfo>	(3) Beginning of navigation		
<Navigation>GO-STRAIGHT</Navigation>	(4) Navigation command	Operator	Menu
<Regulation>ONE-WAY-STREET</Regulation>	(5) Regulation	Operator	Menu
</NaviInfo>	(6) End of navigation		
<RoadInfo>	(7) Beginning of Road infor.		
<RoadKind>OUTDOOR</RoadKind>	(8) Road kind	Operator	Menu
<Pave>ASPHALT</Pave>	(9) Pavement	Operator	Menu
<Width>	(10) Beginning of width infor.		
<Wide>500</Wide>	(11) Width of road in cm	Operator	Keyboard
<Boundary>300</Boundary>	(12) Distance from boundary	Operator	Keyboard
</Width>	(13) End of width info.		
</RoadInfo>	(14) End of road information		
<PointInfo>	(15) Beginning of points info.		
<Point1>	(16) Beginning of start point	Operator	Menu
<PointX>22</PointX>	(17) X coordinates in cm		
<PointY>60</PointY>	(18) Y coordinates in cm		
<PointDir>0</PointDir>	(19) Heading in degree		
</Point1>	(20) End of start point		
<Point2>	(21) Beginning of end point	Operator	Menu
<PointX>80</PointX>	(22) X coordinates in cm		
<PointY>60</PointY>	(23) Y coordinates in cm		
<PointDir>0</PointDir>	(24) Heading in degree		
</Point2>	(25) End of end point		
<Height>1</Height>	(26) Ordinal number of floor	Operator	Keyboard
</PointInfo>	(27) End of points information		
<SPInfo>	(28) Beginning of SP		
<CDate>	(29) Beginning of C.date	Robot	
<Date>20000719</Date>	(30) Year. month. date	Robot	
<Weather>FINE</Weather>	(31) Weather	Operator	Menu
</CDate>	(32) End of creation date		
<Category>SIDEWALK</Category>	(33) Category of SP	Operator	Menu
<Name> </Name>	(34) Name of SP	Operator	Menu
<Module>EDGE-DETECTION</Module>	(35) Name of module	Operator	Menu
<Version>1.0</Version>	(36) Version of module	Robot	
<Camera>	(37) Beginning of camera info	Operator	Cursor
<Pan>0</Pan>	(38) Pan in degree		
<Tilt>-10</Tilt>	(39) Tilt in degree		
<Zoom>1</Zoom>	(40) Zooming		
</Camera>	(41) End of camera info.		
<Distance>10</Distance>	(42).Lateral distance of SP	Operator	Menu
<Parameter>	(43) Beginning of SP parameters		
<PointInView>	(44) Beginning of Point in view	Operator	Menu
<PntVid>BOTTOM-CENTER</PntVid>	(45) Point in the image		
<PntVX>10</PntVX>	(46) X of point in pixels		
<PntVY>10</PntVY>	(47) Y of point in pixels		
</PointInView>	(48) End of point in view		
<SearchArea>	(49) Beginning of Search area	Operator	Cursor
<SAreaLeft>0</SAreaLeft>	(50) Left of search area		
<SAreaRight>100</SAreaRight>	(51) Right of search area		
<SAreaTop>1</SAreaTop>	(52) Top of search area		
<SAreaBottom>0</SAreaBottom>	(53) Bottom of search area		
</SearchArea>	(54) End of search area		
</Parameter>	(55) End of parameters		
</SPInfo>	(56) End of SP		

Figure 6. An example of XML representation of the path.

## 6. RESULTS

RoTA was demonstrated in the Conference of Robotics Society of Japan at Tokyo University in Oct. 20<sup>th</sup> 2001. We have established Non Profitable Organization “RoTA Research and Spread Club” in 2002. Feb. In the open ceremony of the club, sixty complete blind elderly people tried RoTA in a small test course. Most of the complete blind people feel it helpful, because RoTA can guard them against the obstacle with its weight. On the other hand, weak-sighted people feel it useless, because it cannot go up and down stairs, cannot go into the vehicle. It takes only a half hour for the visually impaired to learn how to use the robot. Three of the complete blind people want to buy it when it is commercially available.

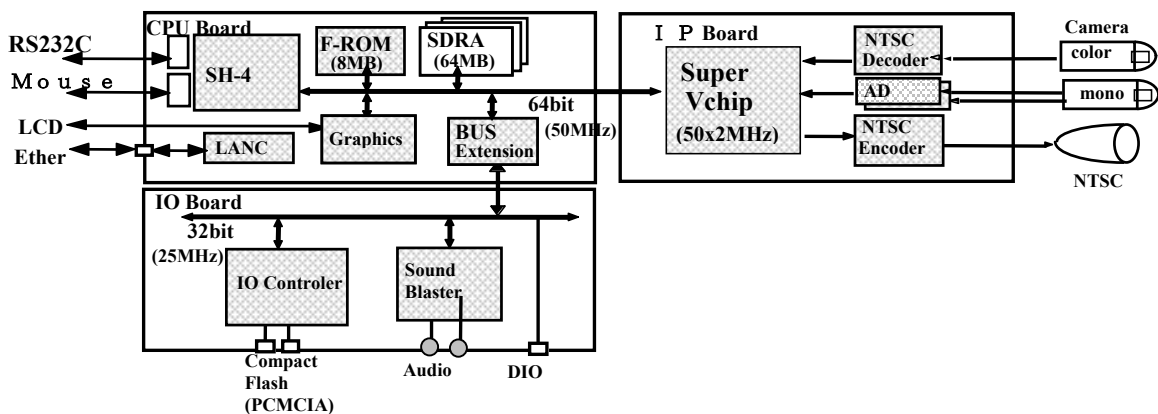

Figure 7. SuperIPcam configuration.

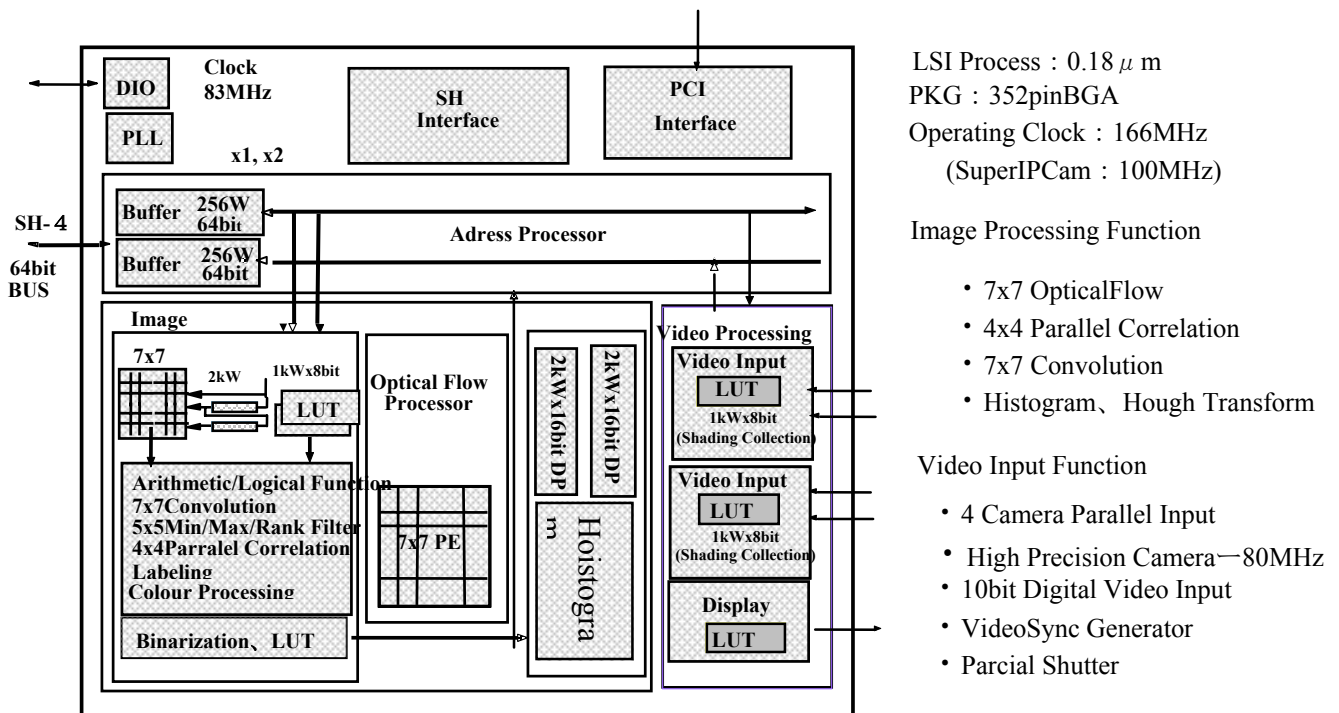

Figure 8. Super V chip configuration.

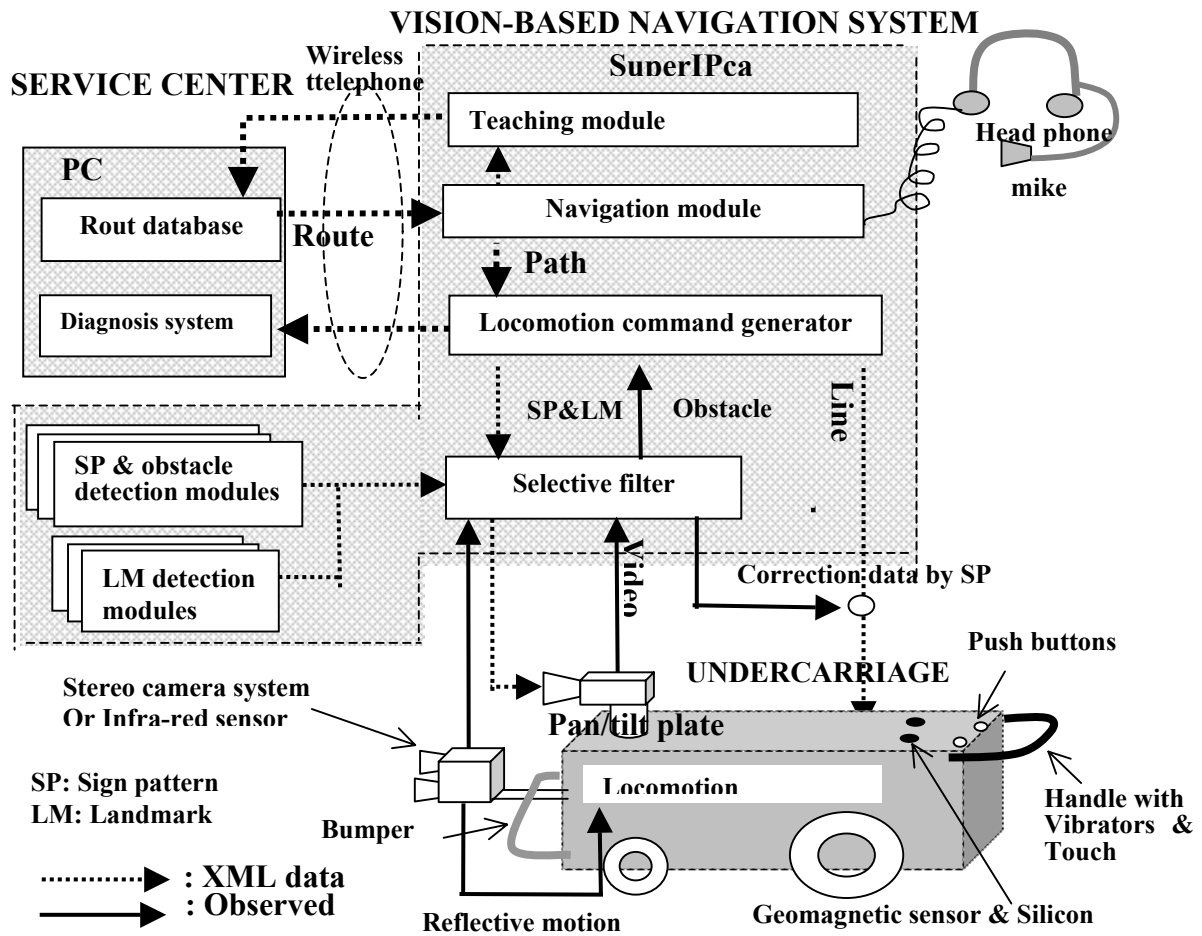

Figure 9. Software system configurations of RoTA and the service center.

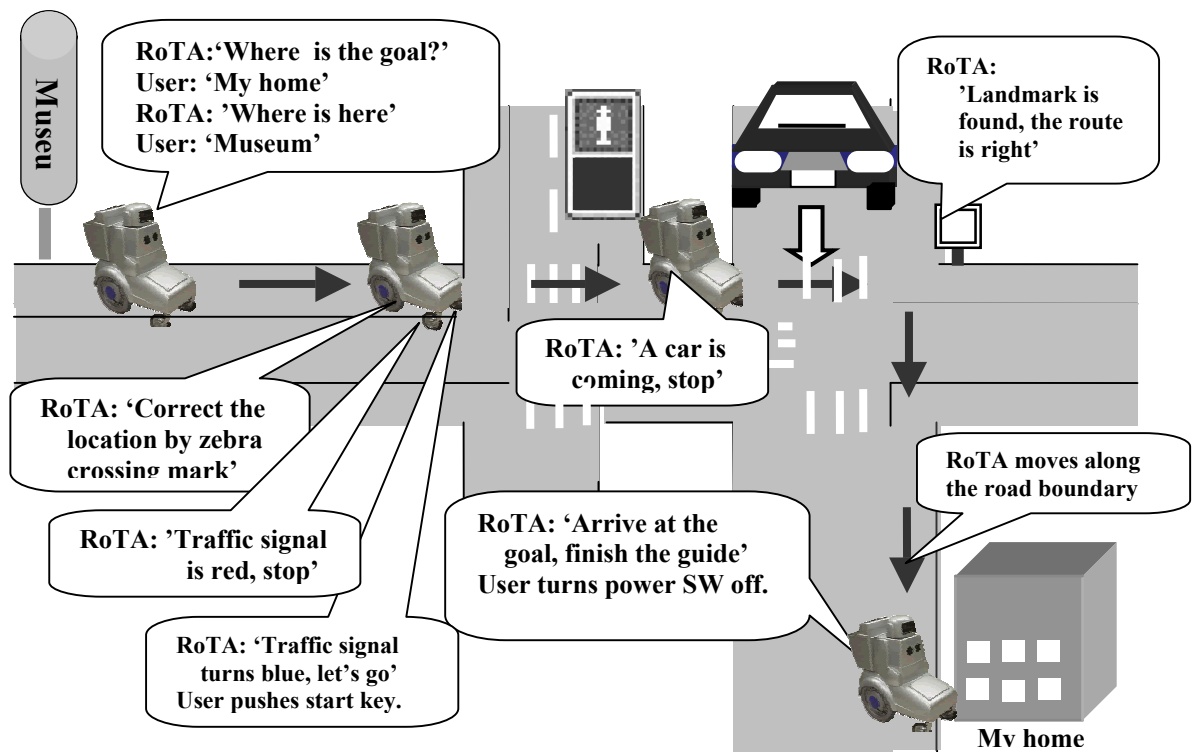

Figure 10. An illustration of the RoTA guide.

One is a man who lives in the senior home with his wife of right sight. The home is good for the robot locomotion, because the route is limited and its corridor is covered with the plain carpet, with little obstacle and of a little traffic.

The second is a woman who opens the clinic of acupuncture and moxibustion in the city of 100,000 populations. She wants to go for a walk with the robot. The road is wide and a little traffic. She walks in the neighborhood with a helper not in the sidewalk but in the road. The application of RoTA is not so difficult from the viewpoint of technology, but it has the problem of traffic regulation. In Japanese regulation, the visually impaired has a long cane or a guide dog when he/she walks in the sidewalk or road.

The third is a woman who manages apartment houses with the guide dog about twenty years, but when she is over seventy years old, she feels difficulty to use the guide dog. She wants to use the robot for a walk in the asphalt-paved road, which runs up and down the hills. This case has the same problem as the second.

The field test of RoTA is to be applied in Hospital of University of Yamanashi this autumn. The inpatient of visually impaired requires a nurse to help his/her walk, so he/she cannot go anytime and anywhere. The robot is a good solution for these problems from the viewpoint of management and service.

## 7. CONCLUSION

We have developed twenty of Robotic Travel Aid (RoTA) in cooperation with three companies for the field. The aim of RoTA is to give a travel aid for the blind people who cannot walk without a helper. One can go to the friend and the drugstore in the neighborhood when and where he wants to go.

At first RoTA will be applied to the hospital or the home to help the blind inpatient or the blind citizen to walk in the indoor. Non Profitable Organization "RoTA Research and Spread Club" will do the field test in the hospital and the home to estimate the service cost of RoTA and will make the business model of RoTA. The club will take action of Japanese traffic regulation revision for the blind to use RoTA in the sidewalk. After the regulation revision the visually impaired can use RoTA by the rental.

The price of RoTA is depend on the number of production. It may be \$20,000 for 50 sets and \$10,000 for more than 100 sets.

**Acknowledgements.** This project is financially supported by NEDO (MITI) and JSPS (Ministry of Education) in 2000 and worked in co-operation with Hitach Ltd. Hitach Laboratory, Suzuki Motor Corporation Yokohama R&D Center, Nippon Systemware Co. Ltd., Professor H. Sanada of Musashino Art University and Professor K. Saneyoshi of Tokyo Institute of Technology under the project leader H. Mori of Yamanashi University.

## 8. REFERENCES

- A. O'Neill, H. Petrie, et.al., Establishing initial user requirements for PAM-AID: a mobility and support device to assist frail and elderly visually impaired persons, Improving the quality of life the European citizen, IOS Press, pp.292-295, 1998
- K. Melen, Independent Transport for Persons with Severe Multiple Disabilities –The "Slingan" Project,ibid, pp.322-326, 1998
- N. Katevas, Sensor Aided Intelligent Wheelchair Navigation System: The results, ibid, p.327-330,1998
- H. Mori, N. M. Charkari and T. Matsushita, On-Line Vehicle and Pedestrian Detection Based on Sign Pattern, IEEE Transaction on Industrial Electronics, Vol. 41, No. 4, pp.384-391, 1994
- S. Kotani, H. Mori, A. M. Charkari, Danger estimation of the Robotic Travel Aid (RoTA) at intersection, Robotics and Autonomous System 18 ,pp.235-242. 1996
- S. Kotani, H. Mori and N. Kiyohiro, Development of the robotic travel aid "HITOMI", Robotics and Autonomous System 17, pp.119-128, 1996
- Y. Yasutomi, H. Mori, S.Kotani, Finding pedestrian by estimation temporal-frequency and spatial-period of the moving objects, ibid, pp.25-34, 1996